

Product Specification



Gleichmann & Co. Electronics GmbH  
Product Marketing Displays & Systems  
Schraderstr. 44, D- 67227 Frankenthal  
Tel : +49 7249-910-0, Fax: +49 7249-910-559  
[display@msc-ge.com](mailto:display@msc-ge.com) <http://www.msc-ge.com>

# SPECIFICATION FOR APPROVAL

- ( ● ) Preliminary Specification
- (   ) Final Specification

Title	27.0" QHD TFT LCD
-------	-------------------

BUYER	General
MODEL	

SUPPLIER	LG Display Co., Ltd.
*MODEL	LM270WQ2
SUFFIX	SLA1

\*When you obtain standard approval,  
please use the above model name without suffix

APPROVED BY	SIGNATURE DATE
/	_____
/	_____
/	_____

APPROVED BY	SIGNATURE DATE
J. H. Park / G.Manager	_____
<b>REVIEWED BY</b>	
S. J. So / Manager	_____
<b>PREPARED BY</b>	
K. H. Lee / Engineer	_____

Please return 1 copy for your confirmation with your signature and comments.

**MNT Products Engineering Dept.**  
**LG Display Co., Ltd.**

**Product Specification**
Contents

No	ITEM	Page
	COVER	1
	CONTENTS	2
	RECORD OF REVISIONS	3
1	GENERAL DESCRIPTION	4
2	ABSOLUTE MAXIMUM RATINGS	5
3	ELECTRICAL SPECIFICATIONS	6
3-1	ELECTRICAL CHARACTERISTICS	6
3-2	INTERFACE CONNECTIONS	8
3-3	LVDS CHARACTERISTICS	11
3-4	SIGNAL TIMING SPECIFICATIONS	14
3-5	SIGNAL TIMING WAVEFORMS	15
3-6	COLOR INPUT DATA REFERENCE	16
3-7	POWER SEQUENCE & DIP CONDITION FOR LCD MODULE	17
3-8	POWER SEQUENCE & DIP CONDITION FOR LCD INVERTER	19
4	OPTICAL SPECIFICATIONS	20
5	MECHANICAL CHARACTERISTICS	26
6	RELIABILITY	29
7	INTERNATIONAL STANDARDS	30
7-1	SAFETY	30
7-2	EMC	30
7-3	ENVIRONMENT	30
8	PACKING	31
8-1	DESIGNATION OF LOT MARK	31
8-2	PACKING FORM	31
9	PRECAUTIONS	32
9-1	MOUNTING PRECAUTIONS	32
9-2	OPERATING PRECAUTIONS	32
9-3	ELECTROSTATIC DISCHARGE CONTROL	33
9-4	PRECAUTIONS FOR STRONG LIGHT EXPOSURE	33
9-5	STORAGE	33
9-6	HANDLING PRECAUTIONS FOR PROTECTION FILM	33



**Product Specification**

**1. General Description**

The LM270WQ2 is a Color Active Matrix Liquid Crystal Display with an integral Cold Cathode Fluorescent Lamp (CCFL) backlight system. The matrix employs a-Si Thin Film Transistor as the active element. It is a transmissive type display operating in the normally black mode. It has a 27inch diagonally measured active display area with QHD resolution (2560 vertical by 1440 horizontal pixel array) Each pixel is divided into Red, Green and Blue sub-pixels or dots which are arranged in vertical stripes. Gray scale or the brightness of the sub-pixel color is determined with a 10-bit gray scale signal for each dot, thus, presenting a palette of more than 1.07Billion colors with Advanced-FRC (Frame Rate Control). It has been designed to apply the 10-bit 4 port LVDS interface. It is intended to support displays where high brightness, super wide viewing angle, high color saturation, and high color are important.

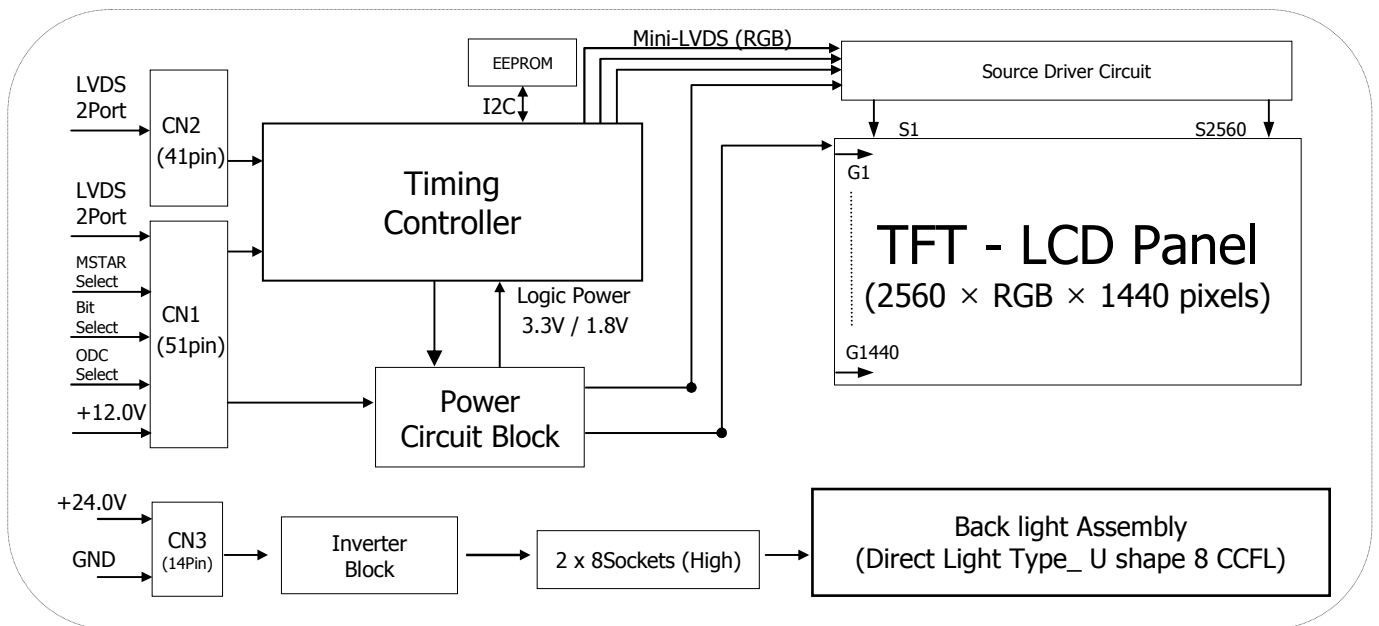

**General Features**

Active Screen Size	26.96 inches (68.47cm) diagonal
Outline Dimension	630.0(H) x 368.2(V) x 42.7(D) mm(Typ.), with inverter
Pixel Pitch	0.2331 mm x 0.2331 mm
Pixel Format	2560 horiz. By 1440 vert. Pixels RGB stripes arrangement
Color Depth	1.07 Billion colors, 10Bit with A-FRC
Luminance, White	350 cd/m <sup>2</sup> (Center 1Point, Typ.)
Viewing Angle(CR>10)	View Angle Free (R/L 178(Typ.), U/D 178(Typ.))
Power Consumption	Total 100.5Watt (Typ.) (14.1Watt @V <sub>LCD</sub> , 86.4Watt @350 cd/ m <sup>2</sup> )
Weight	4,190g (Typ.)
Display Operating Mode	Transmissive mode, normally black
Surface Treatment	Hard coating(3H), Anti-glare treatment of the front polarizer

Product Specification

**2. Absolute Maximum Ratings**

The following are maximum values which, if exceeded, may cause faulty operation or damage to the unit.

**Table 1. ABSOLUTE MAXIMUM RATINGS**

Parameter	Symbol	Values		Units	Notes
		Min	Max		
Power Input Voltage	V <sub>LCD</sub>	-0.3	14	V <sub>dc</sub>	at 25 ± 2°C
Operating Temperature	T <sub>OP</sub>	0	50	°C	1
Storage Temperature	T <sub>ST</sub>	-20	60	°C	
Operating Ambient Humidity	H <sub>OP</sub>	10	90	%RH	
Storage Humidity	H <sub>ST</sub>	10	90	%RH	

Note : 1. Temperature and relative humidity range are shown in the figure below.  
Wet bulb temperature should be 39 °C Max, and no condensation of water.

**FIG. 1 Temperature and relative humidity**

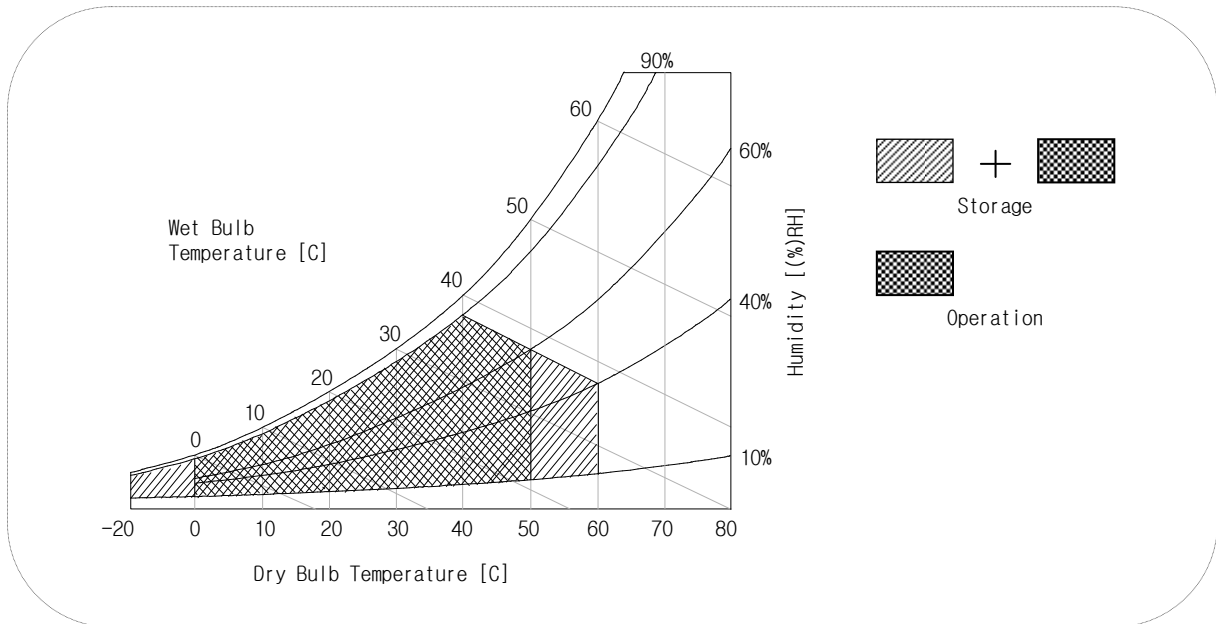

Product Specification

**3. Electrical Specifications**

**3-1. Electrical Characteristics**

It requires two power inputs. One is employed to power the LCD electronics and to drive the TFT array and liquid crystal. The second input power for the CCFL/Backlight, is typically generated by an inverter. The inverter is an external unit to the LCDs.

**Table 2-1. ELECTRICAL CHARACTERISTICS**

Parameter	Symbol	Values			Unit	Notes
		Min	Typ	Max		
MODULE :						
Power Supply Input voltage	VLCD	11.4	12.0	12.6	Vdc	
Permissive Power Input Ripple	VdRF	-		400	mVp-p	
Power Supply Input Current	ILCD	990	1170	1350	mA	1
		1330	1570	1810	mA	2
Power Consumption	PLCD	-	14.1	16.2	Watt	1
Rush Current	IRUSH_VLCD	-	-	3.0	A	3

Note :

1. The specified current and power consumption are under the  $V_{LCD}=12.0V$ ,  $25 \pm 2^{\circ}C$ ,  $f_v=60Hz$  condition whereas mosaic pattern(8 x 6) is displayed and  $f_v$  is the frame frequency.
2. The current is specified at the maximum current pattern.
3. The duration of rush current is about 2ms and rising time of power Input is 1ms(min.).

**FIG.2 pattern for Electrical characteristics**

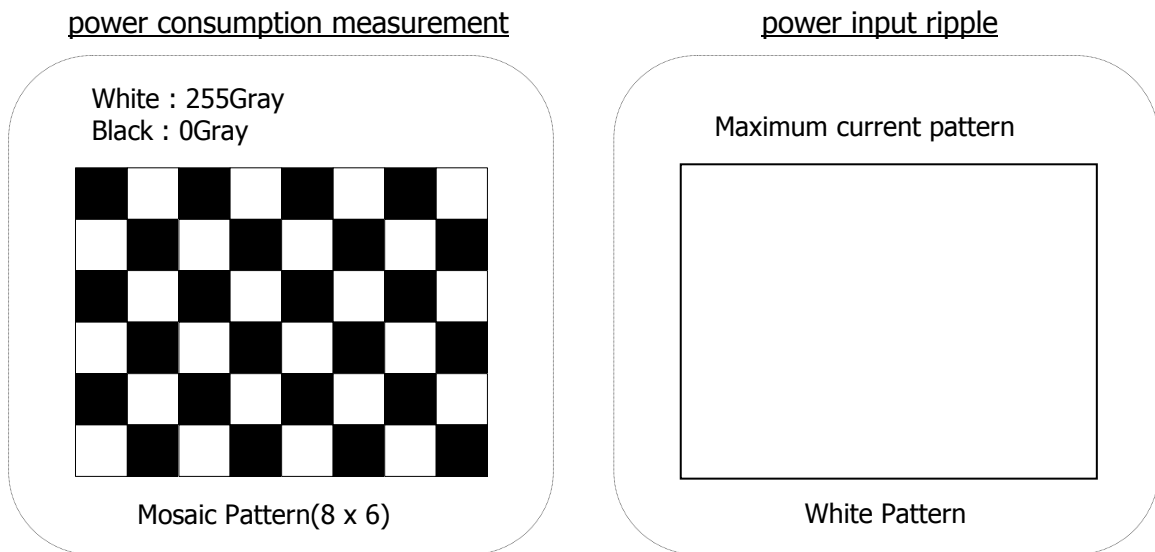

**Product Specification**
**Table 2-2. INVERTER ELECTRICAL CHARACTERISTICS**

Parameter	Symbol	Condition	Values			Unit	Notes
			Min.	Typ.	Max.		
<b>Inverter :</b>							
Input Voltage	$V_{DDB}$	-	21.6	24.0	26.4	V	1
Input Current	$I_{DDB}$	$V_{in}=24V, V_{BR}=3.3V (D=100\%)$	-	3.6	-	A	2
Input Power	$P_B$	$V_{in}=24V, V_{BR}=3.3V (D=100\%)$	-	86.4	-	Watt	2
B/L on/off control	VON/OFF	Lamp ON = High	2.4	-	5.0	V	
		Lamp OFF =Low	-0.3	-	0.8	V	
Brightness Adj	$V_{BR}$	Ext. PWM	25		100	%	On Duty
PWM Frequency	$F_b$			180		Hz	3
<b>LAMP :</b>							
Life time			40,000			Hrs	4

**Notes :**

- The input voltage ripple is limited below 400mVp-p.
- The specified current and power consumption are under the typical supply Input voltage, 24V.
- Voltage and current is measured for Asymmetry ratio and Distortion ratio.  
 Asymmetry Ratio:  $|I_{peak} - I_{-peak}| / I_L$       Distortion Ratio :  $|I_{peak}| (or I_{-peak}) / I_L$
- The life is determined as the time at which luminance of the lamp is 50% compared to that of initial value at the typical lamp current on condition of continuous operating at  $25 \pm 2^\circ C$ .
- Electrical characteristics are determined after the unit has been 'ON' and stable for approximately 30min in a dark environment at  $25 \pm 2^\circ C$ .
- In case of the difference in measured values due to the difference of measuring device was found, correlated value will be used after discussions between both parties.

**Product Specification**

### 3-2. Interface Connections

This LCD module employs two kinds of interface connection, 51-pin and 41-pin connectors are used for the module electronics and 14-pin connectors are used for the integral backlight system.

#### 3-2-1. LCD Module (CN1, CN2)

- LCD Connector(CN1): IS050-C51B-C39-A(manufactured by UJU) or FI-RE51S-HF(manufactured by JAE) or compatible. Refer to below and next Page table.
- Mating Connector : FI-RE51HL(JAE) or compatible

**Table 3-1. MODULE CONNECTOR(CN1) PIN CONFIGURATION**

No	Symbol	Description	No	Symbol	Description
1	GND	Ground	27	Bit Select	'H' = 10bit , 'L' or NC = 8bit
2	NC	No Connection	28	R2AN	SECOND LVDS Receiver Signal (A-)
3	NC	No Connection	29	R2AP	SECOND LVDS Receiver Signal (A+)
4	NC	No Connection	30	R2BN	SECOND LVDS Receiver Signal (B-)
5	NC	No Connection	31	R2BP	SECOND LVDS Receiver Signal (B+)
6	ODC Select	'H' or NC = Enable , 'L' = Disable	32	R2CN	SECOND LVDS Receiver Signal (C-)
7	LVDS Format	'H'= MSTAR Concept , 'L'=normal	33	R2CP	SECOND LVDS Receiver Signal (C+)
8	NC	No Connection	34	GND	Ground
9	PWM_OUT	Reference signal for inverter control	35	R2CLKN	SECOND LVDS Receiver Clock Signal(-)
10	NC	No Connection	36	R2CLKP	SECOND LVDS Receiver Clock Signal(+)
11	GND	Ground	37	GND	Ground
12	R1AN	FIRST LVDS Receiver Signal (A-)	38	R2DN	SECOND LVDS Receiver Signal (D-)
13	R1AP	FIRST LVDS Receiver Signal (A+)	39	R2DP	SECOND LVDS Receiver Signal (D+)
14	R1BN	FIRST LVDS Receiver Signal (B-)	40	R2EN	SECOND LVDS Receiver Signal (E-)
15	R1BP	FIRST LVDS Receiver Signal (B+)	41	R2EP	SECOND LVDS Receiver Signal (E+)
16	R1CN	FIRST LVDS Receiver Signal (C-)	42	Reserved	No connection or GND
17	R1CP	FIRST LVDS Receiver Signal (C+)	43	Reserved	No connection or GND
18	GND	Ground	44	GND	Ground
19	R1CLKN	FIRST LVDS Receiver Clock Signal(-)	45	GND	Ground
20	R1CLKP	FIRST LVDS Receiver Clock Signal(+)	46	GND	Ground
21	GND	Ground	47	NC	No connection
22	R1DN	FIRST LVDS Receiver Signal (D-)	48	VLCD	Power Supply +12.0V
23	R1DP	FIRST LVDS Receiver Signal (D+)	49	VLCD	Power Supply +12.0V
24	R1EN	FIRST LVDS Receiver Signal (E-)	50	VLCD	Power Supply +12.0V
25	R1EP	FIRST LVDS Receiver Signal (E+)	51	VLCD	Power Supply +12.0V
26	Reserved	No connection or GND	-	-	-

- Notes :
1. All GND(ground) pins should be connected together to the LCD module's metal frame.
  2. All V<sub>LC</sub>D (power input) pins should be connected together.
  3. All Input levels of LVDS signals are based on the EIA 644 Standard.
  4. Specific pins(pin No. #2~#6) are used for internal data process of the LCD module.  
If not used, these pins are no connection.
  5. LVDS pin (pin No. #24,25,40,41) are used for 10Bit(D) of the LCD module.  
If used for 8Bit(R), these pins are no connection.
  6. Specific pin No. #44 is used for "No signal detection" of system signal interface.  
It should be GND for NSB(No Signal Black) during the system interface signal is not.  
If this pin is "H", LCD Module displays AGP(Auto Generation Pattern).



**Product Specification**

- LCD Connector(CN2): IS050-C41B-C39-A(manufactured by UJU) or FI-RE41S-HF(manufactured by JAE) or compatible. Refer to below table.
- Mating Connector : FI-RE41HL or compatible.

**Table 3-2. MODULE CONNECTOR(CN2) PIN CONFIGURATION**

No	Symbol	Description	No	Symbol	Description
1	NC	No connection(Reserved)	22	R3EN	THIRD LVDS Receiver Signal (E-)
2	NC	No connection	23	R3EP	THIRD LVDS Receiver Signal (E+)
3	NC	No connection	24	GND	Ground
4	NC	No connection	25	GND	Ground
5	NC	No connection	26	R4AN	FORTH LVDS Receiver Signal (A-)
6	NC	No connection	27	R4AP	FORTH LVDS Receiver Signal (A+)
7	NC	No connection	28	R4BN	FORTH LVDS Receiver Signal (B-)
8	NC	No connection	29	R4BP	FORTH LVDS Receiver Signal (B+)
9	GND	Ground	30	R4CN	FORTH LVDS Receiver Signal (C-)
10	R3AN	THIRD LVDS Receiver Signal (A-)	31	R4CP	FORTH LVDS Receiver Signal (C+)
11	R3AP	THIRD LVDS Receiver Signal (A+)	32	GND	Ground
12	R3BN	THIRD LVDS Receiver Signal (B-)	33	R4CLKN	FORTH LVDS Receiver Clock Signal(-)
13	R3BP	THIRD LVDS Receiver Signal (B+)	34	R4CLKP	FORTH LVDS Receiver Clock Signal(+)
14	R3CN	THIRD LVDS Receiver Signal (C-)	35	GND	Ground
15	R3CP	THIRD LVDS Receiver Signal (C+)	36	R4DN	FORTH LVDS Receiver Signal (D-)
16	GND	Ground	37	R4DP	FORTH LVDS Receiver Signal (D+)
17	R3CLKN	THIRD LVDS Receiver Clock Signal(-)	38	R4EN	FORTH LVDS Receiver Signal (E-)
18	R3CLKP	THIRD LVDS Receiver Clock Signal(+)	39	R4EP	FORTH LVDS Receiver Signal (E+)
19	GND	Ground	40	GND	Ground
20	R3DN	THIRD LVDS Receiver Signal (D-)	41	GND	Ground
21	R3DP	THIRD LVDS Receiver Signal (D+)	-		

- Notes : 1. All GND(ground) pins should be connected together to the LCD module’s metal frame.  
 2. LVDS pin (pin No. #22,23,38,39) are used for 10Bit(D) of the LCD module.  
 If used for 8Bit(R), these pins are no connection.

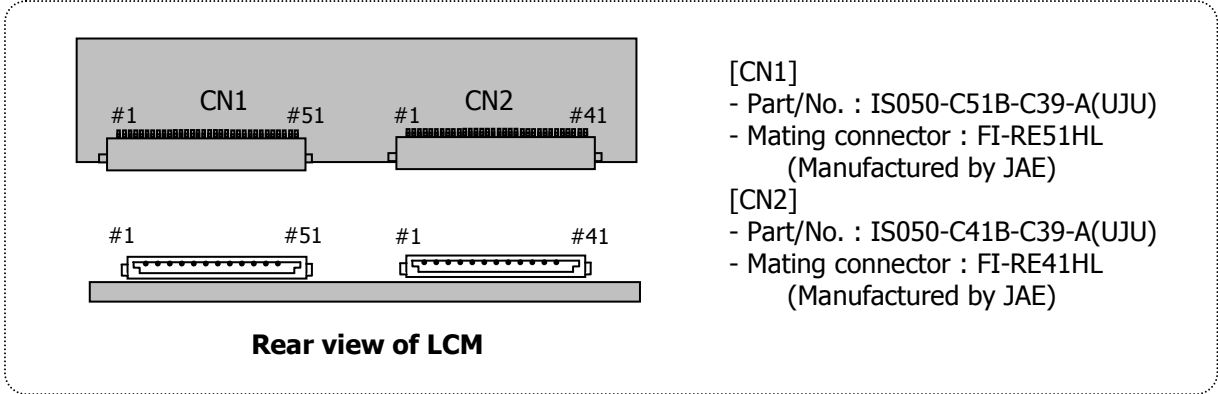

Product Specification

**3-2-2. Inverter Connector for Backlight**

- Inverter Connector : 20022WR-14A00(manufactured by YEONHO) or S14B-PH-SM3(manufactured by JST)
- or compatible. Refer to below table.
- Mating Connector : PHR14(JST) or compatible

**Table 3-2. INVERTER CONNECTOR PIN CONFIGURATION**

No	Symbol	Description	Notes
1	V <sub>BL</sub>	Power Supply, +24V	
2	V <sub>BL</sub>	Power Supply, +24V	
3	V <sub>BL</sub>	Power Supply, +24V	
4	V <sub>BL</sub>	Power Supply, +24V	
5	V <sub>BL</sub>	Power Supply, +24V	
6	GND	Power Ground	
7	GND	Power Ground	
8	GND	Power Ground	
9	GND	Power Ground	
10	GND	Power Ground	
11	NC	No connection	
12	V <sub>ON/OFF</sub>	BL On/Off Control signal	ON : 2.0V~5.0V OFF : 0.0~0.8V
13	V <sub>BR</sub>	PWM Dimming Control Signal	Max: 3.3V Min : 0.0V
14	Status	No connection	Normal =0~0.8V Abnormal=3.0~5.0V

- Notes :
1. GND is connected to the LCD's metal frame.
  2. V<sub>BR</sub> input is PWM signal (180Hz) and the signal level is within 3.3V ± 3%.  
PWM Duty : Max 100% / Min 25%

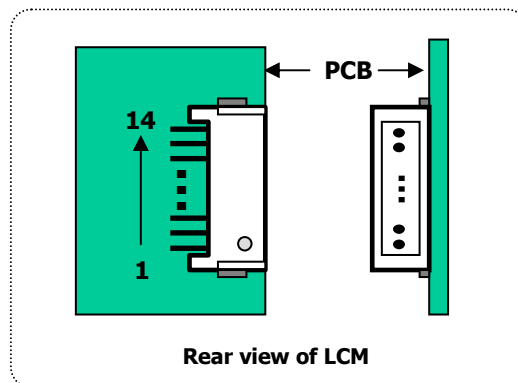

Product Specification

**3-3. LVDS characteristics**

**3-3-1. DC Specification**

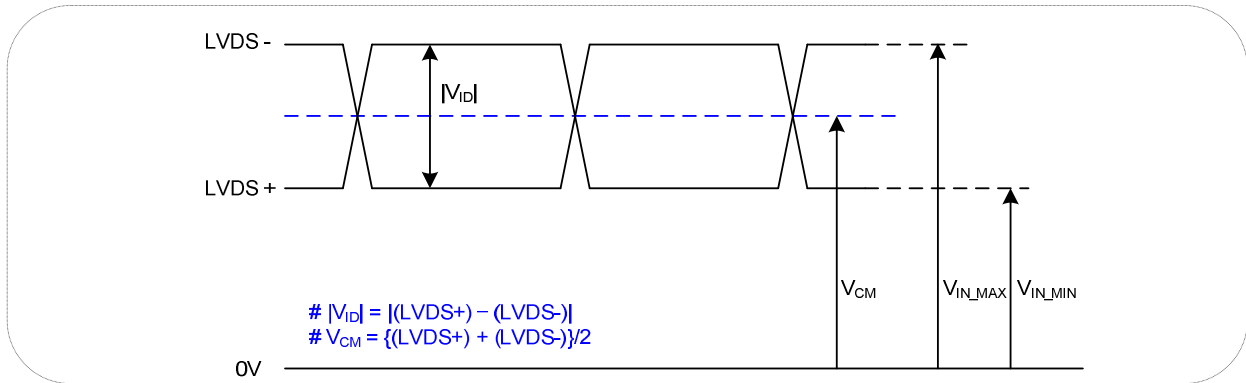

Description	Symbol	Min	Max	Unit	Notes
LVDS Differential Voltage	$ V_{ID} $	200	600	mV	-
LVDS Common mode Voltage	$V_{CM}$	1.0	1.5	V	-
LVDS Input Voltage Range	$V_{IN}$	0.7	1.8	V	-
Change in common mode Voltage	$\Delta V_{CM}$	-	250	mV	-

**3-3-2. AC Specification**

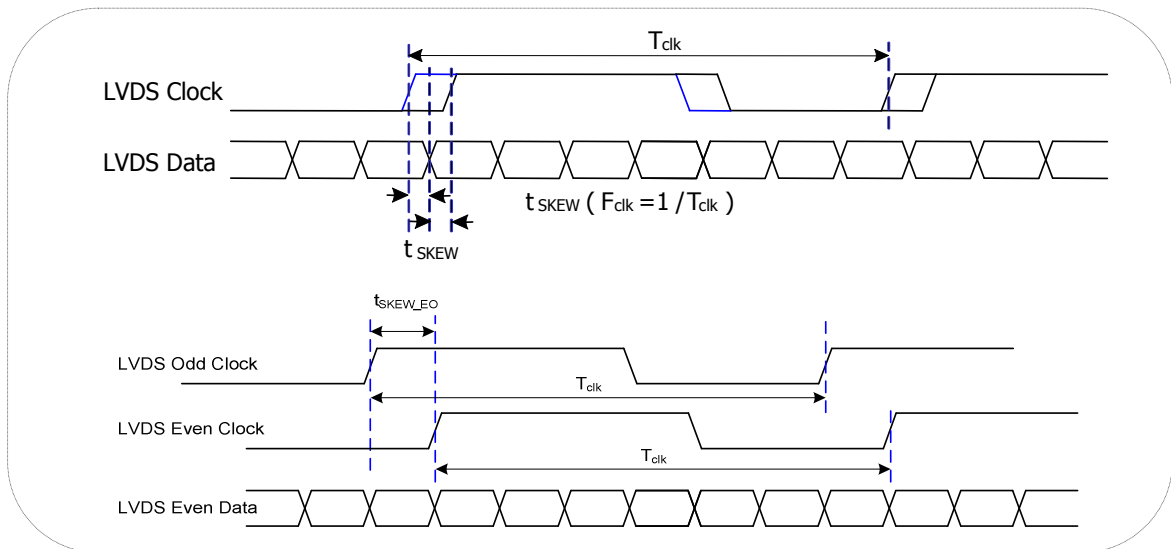

Description	Symbol	Min	Max	Unit	Notes
LVDS Clock to Data Skew Margin	$t_{SKEW}$	$-(0.25 * t_{CLK}) / 7$	$+(0.25 * t_{CLK}) / 7$	ps	
LVDS Clock to Clock Skew Margin	$t_{SKEW\_EO}$	$- 1 / 7$	$+ 1 / 7$	$T_{clk}$	-
Effective time of LVDS	$t_{eff}$	520		ps	-

Product Specification

- LVDS Effective Period

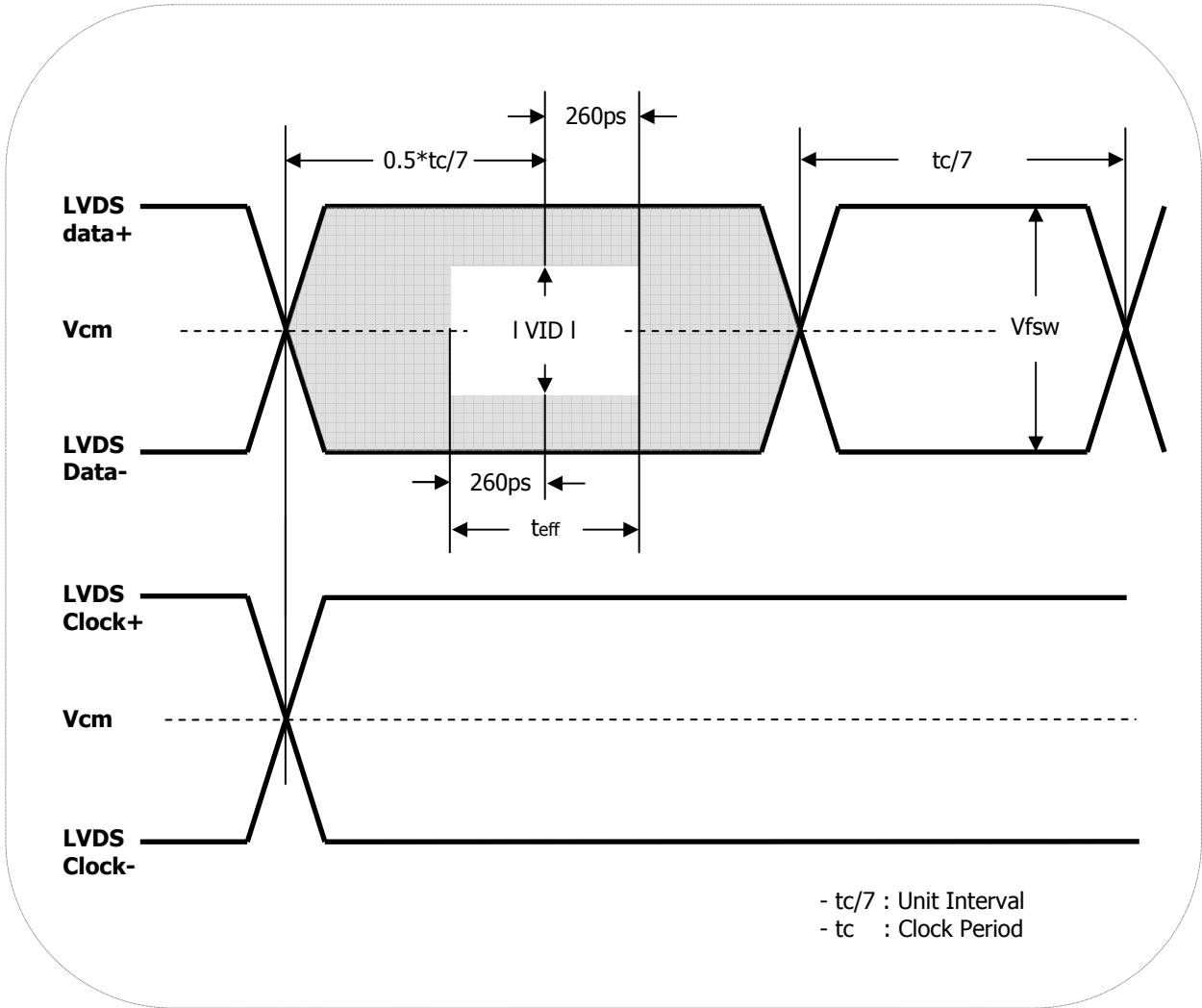

Product Specification

**3-3-3. LVDS Data format (Bit Select)**

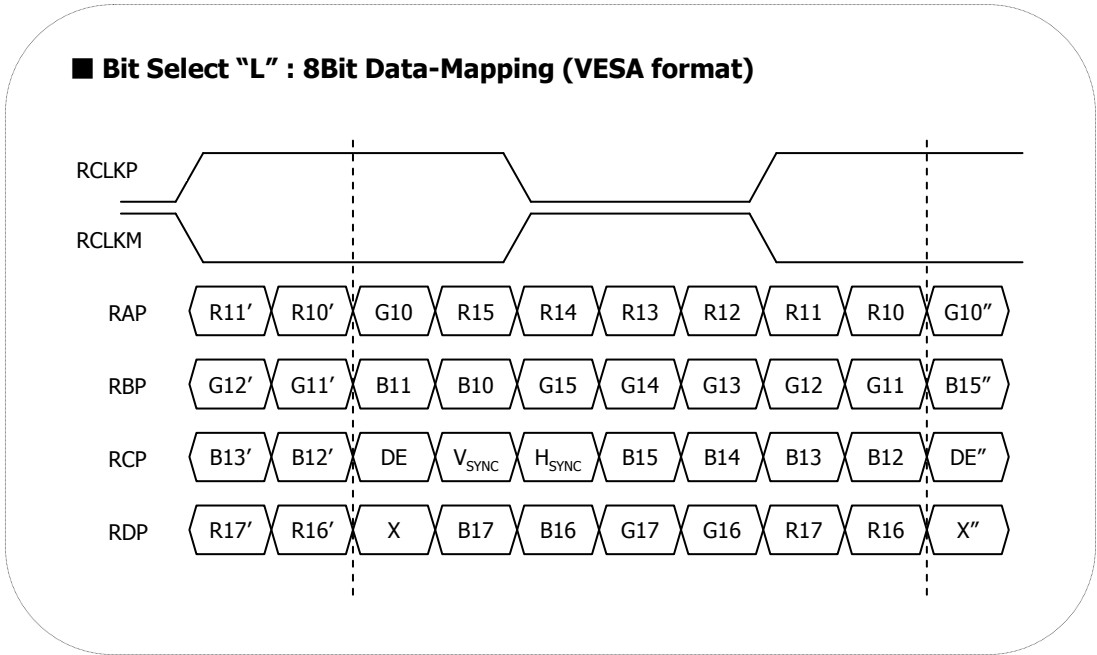
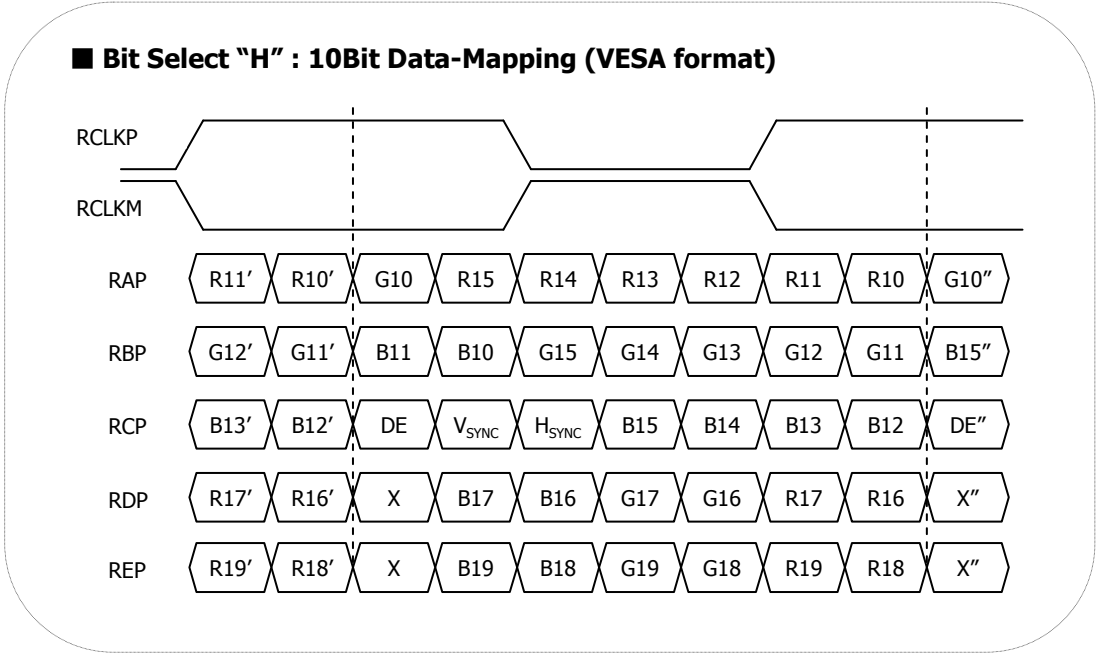

**Product Specification**
**3-4. Signal Timing Specifications**

All of the interface signal timing should be satisfied with the following specifications for its proper operation.

**Table 4. TIMING TABLE (VESA COORDINATED VIDEO TIMING)**

Parameter		Symbol	Min.	Typ.	Max.	Unit	Notes
DCLK	Period	tCLK	16.46	16.56	16.67	ns	Pixel frequency : Typ.241.5MHz
	Frequency	fCLK	60	60.38	60.75	MHz	
Hsync	Period	tHP	678	680	682	tCLK	
	Width-Active	tWH	8	8	8		
Vsync	Period	tVP	1479	1481	1483	tHP	
	Frequency	fV	59.38	59.95	60.12	Hz	
	Width-Active	tWV	5	5	5	tHP	
Data Enable	Horizontal Valid	tHV	640	640	640	tCLK	
	Horizontal Back Porch	tHBP	18	20	22		
	Horizontal Front Porch	tHFP	10	12	14		
	Horizontal Blank	-	36	40	44		tWH+ tHBP+ tHFP
	Vertical Valid	tVV	1440	1440	1440	tHP	
	Vertical Back Porch	tVBP	32	33	34		
	Vertical Front Porch	tVFP	2	3	4		
	Vertical Blank	-	39	41	43		tWV+ tVBP+ tVFP

Note:

1. DE Only mode operation. The input of Hsync & Vsync signal does not have an effect on LCD normal operation.
2. The performance of the electro-optical characteristics may be influenced by variance of the vertical refresh rates.
3. Horizontal period should be even.

Product Specification

**3-5. Signal Timing Waveforms**

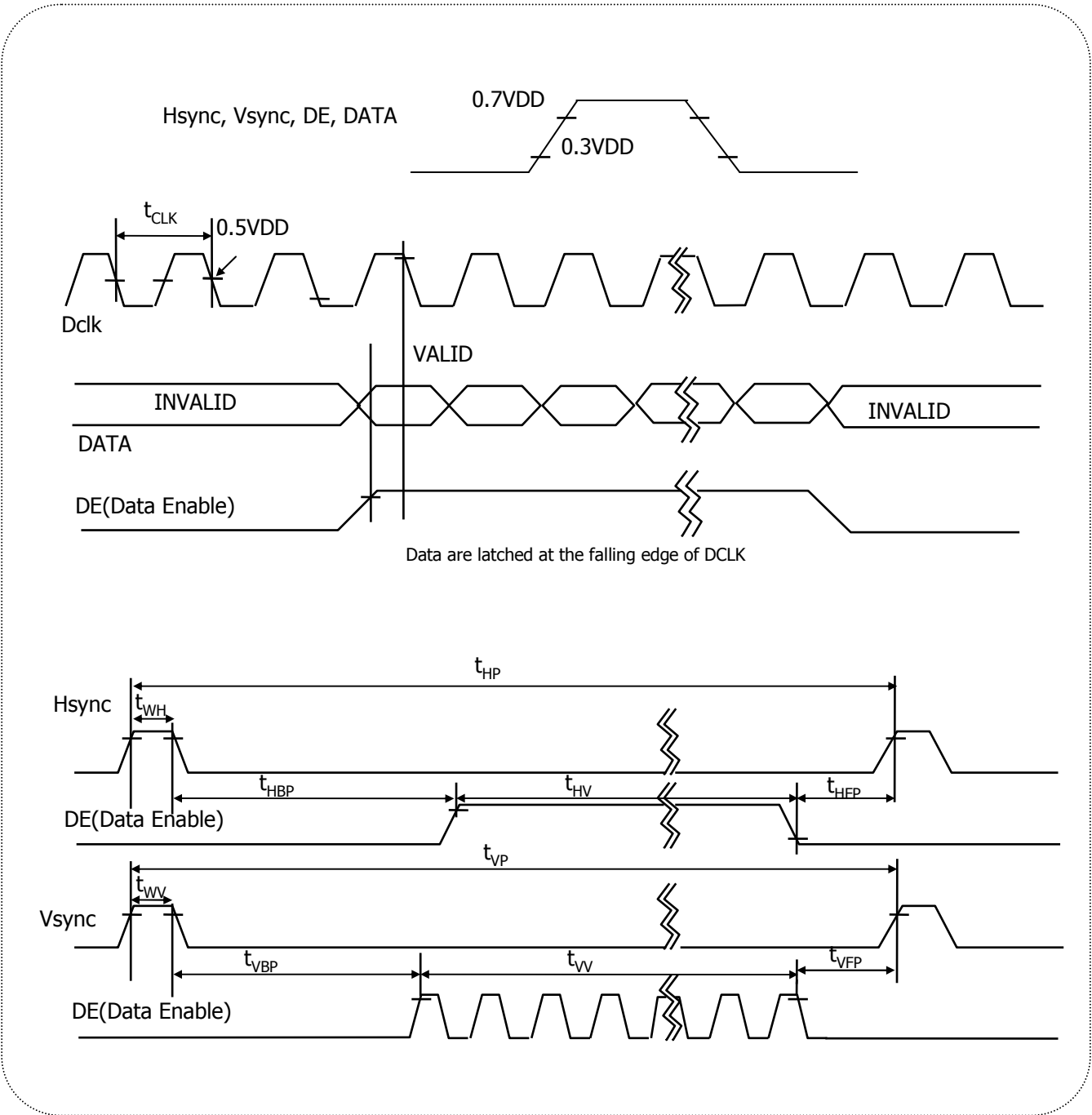

**Product Specification**
**3-6. Color Data Reference**

The Brightness of each primary color(red,green,blue) is based on the 10-bit gray scale data input for the color; the higher the binary input, the brighter the color. The table below provides a reference for color versus data input.

**Table 5. COLOR DATA REFERENCE**

Color		Input Color Data																													
		RED										GREEN										BLUE									
		MSB					LSB					MSB					LSB					MSB					LSB				
		R9	R8	R7	R6	R5	R4	R3	R2	R1	R0	G9	G8	G7	G6	G5	G4	G3	G2	G1	G0	B9	B8	B7	B6	B5	B4	B3	B2	B1	B0
Basic Color	Black	0	0	0	0	0	0	0	0	0	0	0	0	0	0	0	0	0	0	0	0	0	0	0	0	0	0	0	0	0	0
	Red (1023)	1	1	1	1	1	1	1	1	1	1	0	0	0	0	0	0	0	0	0	0	0	0	0	0	0	0	0	0	0	0
	Green (1023)	0	0	0	0	0	0	0	0	0	0	1	1	1	1	1	1	1	1	1	1	0	0	0	0	0	0	0	0	0	0
	Blue (1023)	0	0	0	0	0	0	0	0	0	0	0	0	0	0	0	0	0	0	0	0	1	1	1	1	1	1	1	1	1	1
	Cyan	0	0	0	0	0	0	0	0	0	0	1	1	1	1	1	1	1	1	1	1	1	1	1	1	1	1	1	1	1	1
	Magenta	1	1	1	1	1	1	1	1	1	1	0	0	0	0	0	0	0	0	0	0	1	1	1	1	1	1	1	1	1	1
	Yellow	1	1	1	1	1	1	1	1	1	1	1	1	1	1	1	1	1	1	1	1	0	0	0	0	0	0	0	0	0	0
	White	1	1	1	1	1	1	1	1	1	1	1	1	1	1	1	1	1	1	1	1	1	1	1	1	1	1	1	1	1	1
RED	RED (000)	0	0	0	0	0	0	0	0	0	0	0	0	0	0	0	0	0	0	0	0	0	0	0	0	0	0	0	0	0	
	RED (001)	0	0	0	0	0	0	0	0	0	0	0	0	0	0	0	0	0	0	0	0	0	0	0	0	0	0	0	0	0	
	...	...	...	...	...	...	...	...	...	...	...	...	...	...	...	...	...	...	...	...	...	...	...	...	...	...	...	...	...		
	RED (1022)	1	1	1	1	1	1	1	1	1	0	0	0	0	0	0	0	0	0	0	0	0	0	0	0	0	0	0	0	0	
	RED (1023)	1	1	1	1	1	1	1	1	1	0	0	0	0	0	0	0	0	0	0	0	0	0	0	0	0	0	0	0	0	
GREEN	GREEN (000)	0	0	0	0	0	0	0	0	0	0	0	0	0	0	0	0	0	0	0	0	0	0	0	0	0	0	0	0	0	
	GREEN (001)	0	0	0	0	0	0	0	0	0	0	0	0	0	0	0	0	0	0	0	0	0	0	0	0	0	0	0	0	0	
	...	...	...	...	...	...	...	...	...	...	...	...	...	...	...	...	...	...	...	...	...	...	...	...	...	...	...	...			
	GREEN (1022)	0	0	0	0	0	0	0	0	0	1	1	1	1	1	1	1	1	1	1	0	0	0	0	0	0	0	0	0	0	
	GREEN (1023)	0	0	0	0	0	0	0	0	0	1	1	1	1	1	1	1	1	1	1	0	0	0	0	0	0	0	0	0	0	
BLUE	BLUE (000)	0	0	0	0	0	0	0	0	0	0	0	0	0	0	0	0	0	0	0	0	0	0	0	0	0	0	0	0	0	
	BLUE (001)	0	0	0	0	0	0	0	0	0	0	0	0	0	0	0	0	0	0	0	0	0	0	0	0	0	0	0	0	1	
	...	...	...	...	...	...	...	...	...	...	...	...	...	...	...	...	...	...	...	...	...	...	...	...	...	...	...	...			
	BLUE (1022)	0	0	0	0	0	0	0	0	0	0	0	0	0	0	0	0	0	0	0	1	1	1	1	1	1	1	1	1	0	
	BLUE (1023)	0	0	0	0	0	0	0	0	0	0	0	0	0	0	0	0	0	0	0	1	1	1	1	1	1	1	1	1	1	



Product Specification

**3-7. Power Sequence & Dip condition for LCD Module**

**3-7-1. Power Sequence**

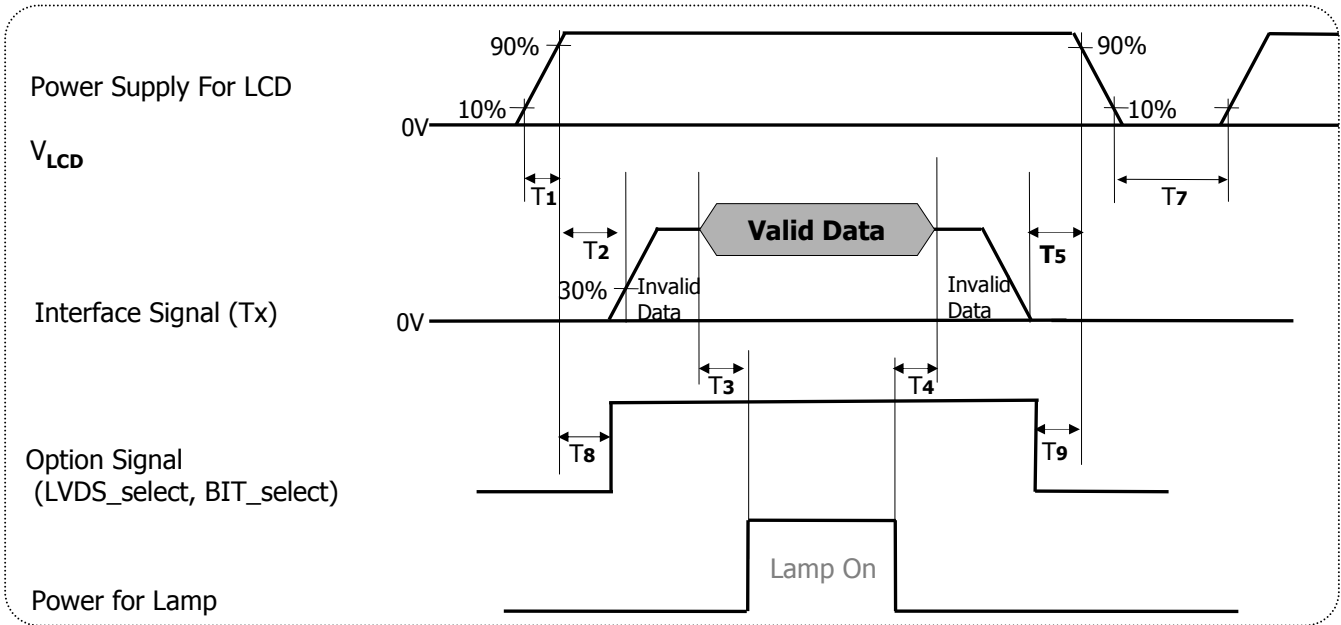
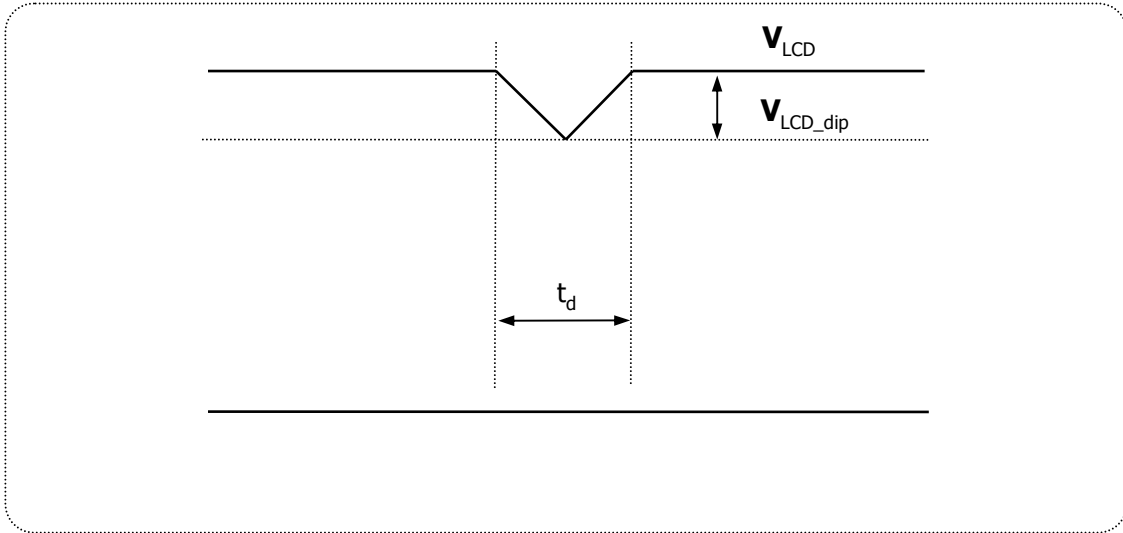

**Table 6. Power sequence**

Parameter	Values			Units
	Min	Typ	Max	
T1	0.5	-	10	ms
T2	0.5	-	50	ms
T3	500	-	-	ms
T4	200	-	-	ms
T5	0.01	-	50	ms
T7	1	-	-	s
T8	0 < T8 < T2			ms
T9	0 < T9 < T5			ms

Notes :

1. Please  $V_{LCD}$  power on only after connecting interface cable to LCD.
2. Please avoid floating state of interface signal at invalid period.
3. When the interface signal is invalid, be sure to pull down the power supply for LCD  $V_{LCD}$  to 0V.
4. Lamp power must be turn on after power supply for LCD an interface signal are valid.

**Product Specification**
**3-7-2. VLCD Power Dip Condition**

Notes :

Dip condition

$$V_{LCD\_dip} \leq V_{LCD\_typ} \times 0.2, \quad t_d \leq 20ms$$

Product Specification

3-8. Power Sequence & Dip condition for Inverter

3-8-1. Power Sequence

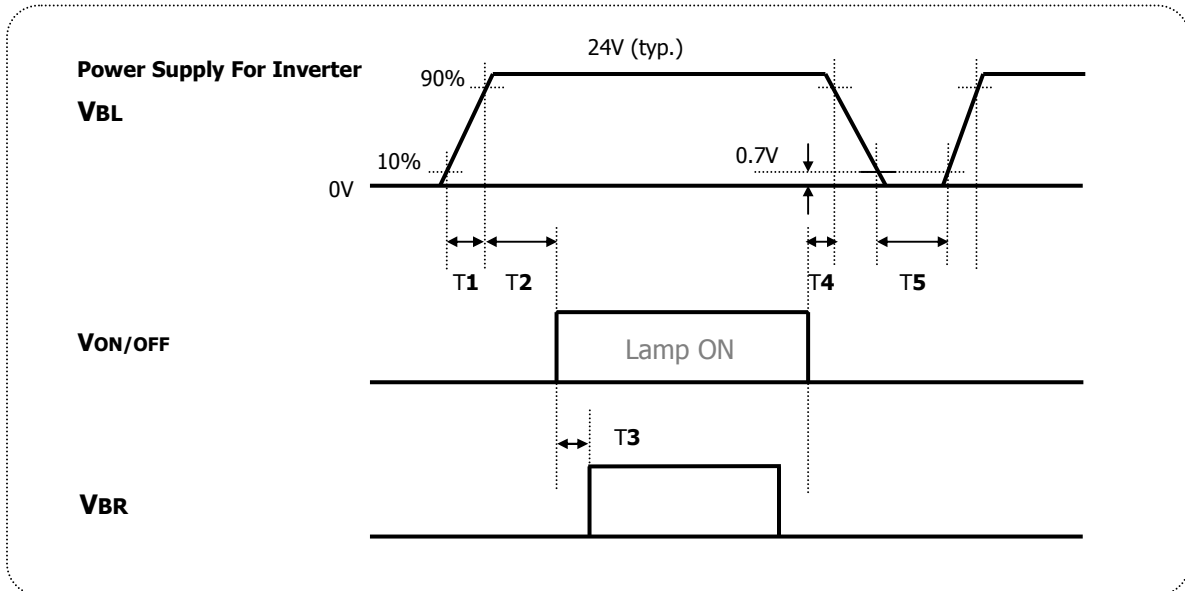

3-8-2. VBL Power Dip Condition

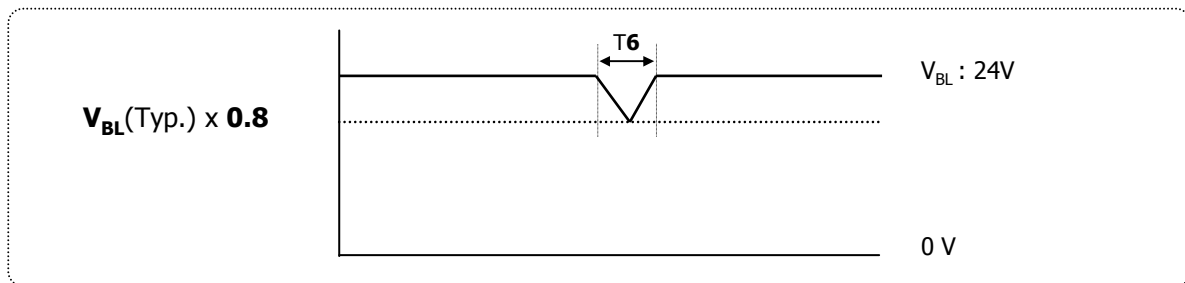

Table 7. Power Sequence for Inverter

Parameter	Values			Units	Remarks
	Min	Typ	Max		
T1	20	-	-	ms	1
T2	500	-	-	ms	
T3	-	-	50	ms	
T4	10	-	-	ms	
T5	500	-	-	ms	
T6	-	-	10	ms	$V_{BL}(Typ) \times 0.8$

Notes : 1. T1 describes rising time of 0V to 24V and this parameter does not applied at restarting time.

**Product Specification**

### 4. Optical Specifications

Optical characteristics are determined after the unit has been 'ON' for approximately 30 minutes in a dark environment at  $25 \pm 2^\circ\text{C}$ . The values specified are at an approximate distance 50cm from the LCD surface at a viewing angle of  $\Phi$  and  $\theta$  equal to  $0^\circ$  and aperture 1 degree.

FIG. 2 presents additional information concerning the measurement equipment and method.

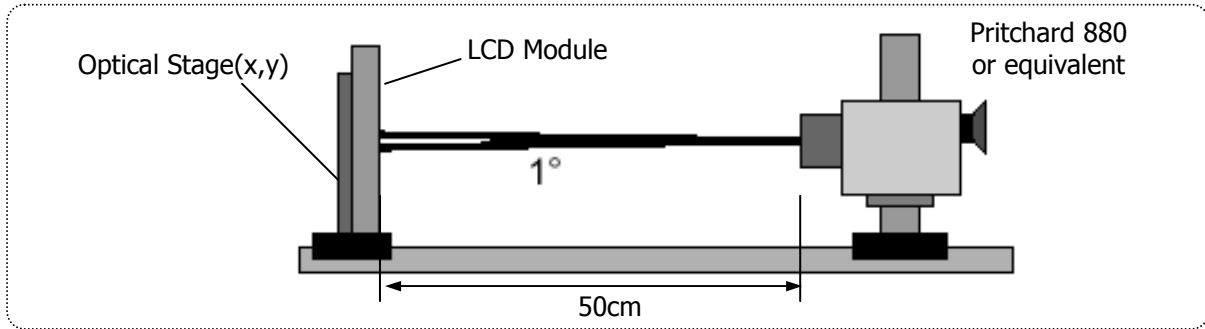

**FIG. 3 Optical Characteristic Measurement Equipment and Method**

**Table 8. OPTICAL CHARACTERISTICS**

( $T_a = 25^\circ\text{C}$ ,  $V_{\text{LCD}} = 12.0\text{V}$ ,  $f_v = 60\text{Hz}$  Dclk=241.5MHz)

Parameter	Symbol	Values			Units	Notes	
		Min	Typ	Max			
Contrast Ratio	CR	700	1000	-		1	
Surface Luminance, white	$L_{\text{WH}}$	280	350	-	cd/m <sup>2</sup>	2	
Luminance Variation	$\delta_{\text{WHITE}}$	75			%	3	
Response Time	Rise Time	$T_{\text{R}}$	-	5.5	12	ms	4
	Decay Time	$T_{\text{D}}$	-	6.5	12	ms	4
	Gray to Gray	$T_{\text{GTG\_AVR}}$	-	6	-	ms	5
		$T_{\text{GTG\_MAX}}$	-	-	12	ms	5
Color Coordinates [CIE1931]	RED	$R_x$	Typ -0.03	0.678	Typ +0.03		
		$R_y$		0.309			
	GREEN	$G_x$		0.202			
		$G_y$		0.689			
	BLUE	$B_x$		0.148			
		$B_y$		0.051			
	WHITE	$W_x$		0.313			
	$W_y$	0.329					
Color Shift	Horizontal	$\theta_{\text{CST\_H}}$	-	178	-	Degree	6
	Vertical	$\theta_{\text{CST\_V}}$	-	178	-		
Viewing Angle (CR>10)							
General	Horizontal	$\theta_{\text{H}}$	170	178	-	Degree	7
	Vertical	$\theta_{\text{V}}$	170	178	-		
Effective	Horizontal	$\theta_{\text{GMA\_H}}$		178	-	Degree	8
	Vertical	$\theta_{\text{GMA\_V}}$		178	-		
Gray Scale				2.2			9

**Product Specification**

Notes 1. Contrast Ratio(CR) is defined mathematically as :

$$\text{Contrast Ratio} = \frac{\text{Surface Luminance with all white pixels}}{\text{Surface Luminance with all black pixels}}$$

It is measured at center point(Location P1)

2. Surface luminance(L<sub>WH</sub>) is luminance value at 5 points average across the LCD surface 50cm from the surface with all pixels displaying white. For more information see FIG 4.

$$L_{WH} = \text{Average}[L_{on1}, L_{on2}, L_{on3}, L_{on4}, L_{on5}]$$

3. The variation in surface luminance,  $\delta$  WHITE is defined as :

$$\delta_{WHITE} = \frac{\text{Minimum}(L_{P1}, L_{P2}, \dots, L_{P9})}{\text{Maximum}(L_{P1}, L_{P2}, \dots, L_{P9})} \times 100$$

Where L1 to L9 are the luminance with all pixels displaying white at 9 locations.  
For more information see FIG 4.

4. Response time is the time required for the display to transition from black to white (Rise Time, Tr<sub>R</sub>) and from white to black (Decay Time, Tr<sub>D</sub>). For additional information see FIG 5.

5. Gray to gray response time is the time required for the display to transition from gray to gray. For additional information see Table 9.

6. Color shift is the angle at which the color difference is lower than 0.04.

For more information see FIG 6.

- Color difference ( $\Delta u'v'$ )

$$u' = \frac{4x}{-2x + 12y + 3} \quad v' = \frac{9y}{-2x + 12y + 3}$$

$$\Delta u'v' = \sqrt{(u'_1 - u'_2)^2 + (v'_1 - v'_2)^2} \quad \begin{array}{l} u'_1, v'_1 : u'v' \text{ value at viewing angle direction} \\ u'_2, v'_2 : u'v' \text{ value at front } (\theta=0) \end{array}$$

- Pattern size : 25% Box size

- Viewing angle direction of color shift : Horizontal, Vertical

7. Viewing angle is the angle at which the contrast ratio is greater than 10. The angles are determined for the horizontal or x axis and the vertical or y axis with respect to the z axis which is normal to the LCD surface. For more information see FIG 7.

8. Effective viewing angle is the angle at which the gamma shift of gray scale is lower than 0.3. For more information see FIG 8 and FIG 9.

9. Gray scale specification

Gamma Value is approximately 2.2. For more information see Table 10.

Product Specification

Measuring point for surface luminance & measuring point for luminance variation.

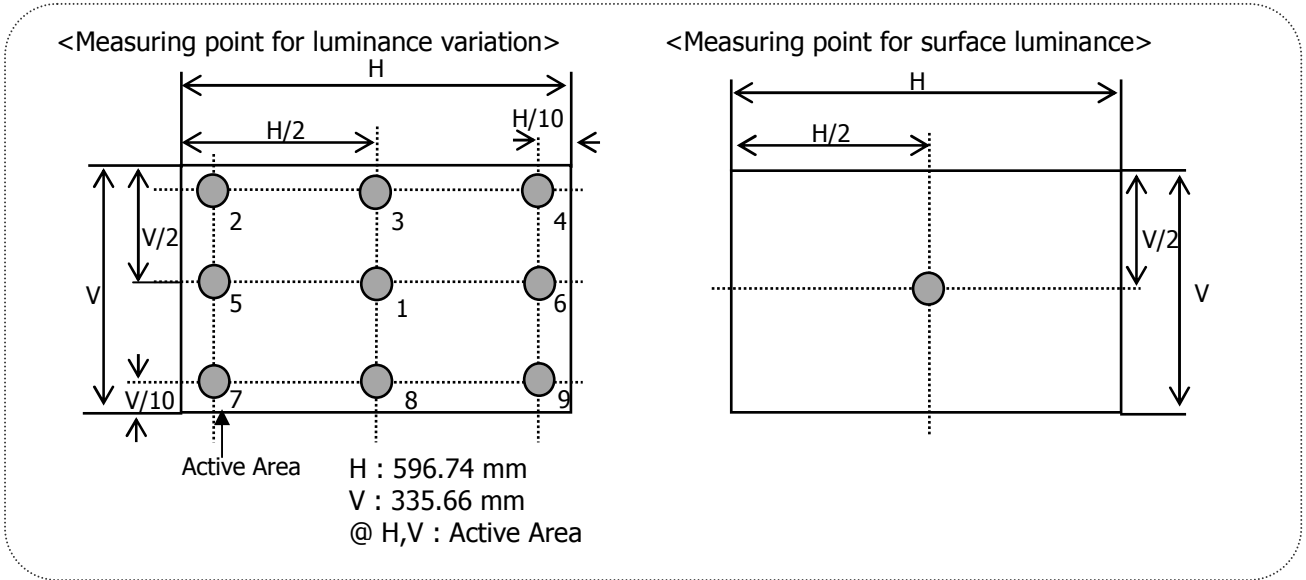

**FIG. 4 Measure Point for Luminance**

The response time is defined as the following figure and shall be measured by switching the input signal for "black" and "white".

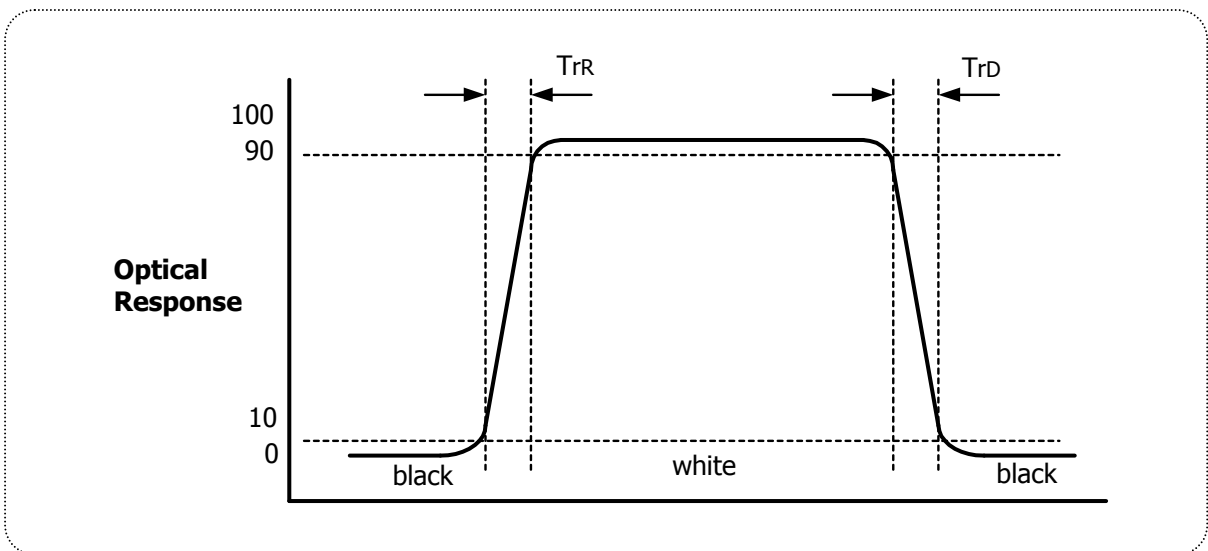

**FIG. 5. Response Time**

**Product Specification**

The gray to gray response time is defined as the following figure and shall be measured by switching the input signal for "Gray To Gray".

- Gray step : 5 step
- T<sub>GTG\_AVR</sub> is the total average time at rising time and falling time for "Gray To Gray".
- T<sub>GTG\_MAX</sub> is the max time at rising time or falling time for "Gray To Gray".

**Table 9. Gray to gray response time table**

Gray to Gray		Rising Time				
		G255	G191	G127	G63	G0
Falling Time	G255					
	G191					
	G127					
	G63					
	G0					

Color shift is defined as the following test pattern and color.

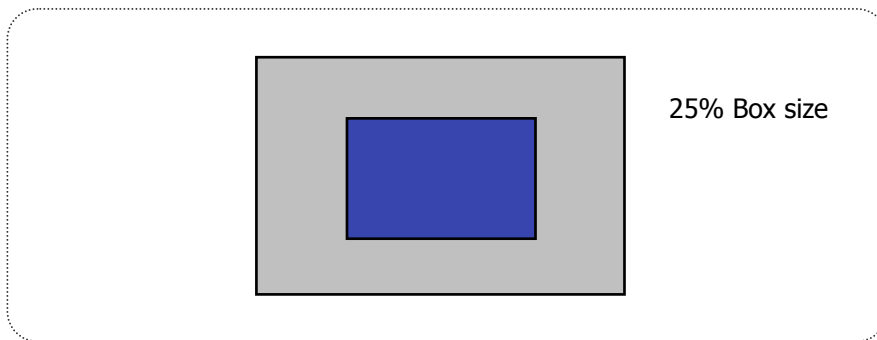

**FIG. 6 Test Pattern**

Average RGB values in Bruce RGB for Macbeth Chart

	Dark skin	Light skin	Blue sky	Foliage	Blue flower	Bluish green
R	98	206	85	77	129	114
G	56	142	112	102	118	199
B	45	123	161	46	185	178
	Orange	Purplish blue	Moderate red	Purple	Yellow green	Orange yellow
R	219	56	211	76	160	230
G	104	69	67	39	193	162
B	24	174	87	86	58	29
	Blue	Green	Red	Yellow	Magenta	cyan
R	26	72	197	241	207	35
G	32	148	27	212	62	126
B	145	65	37	36	151	172
	White	Neutral 8	Neutral 6.5	Neutral 5	Neutral 3.5	black
R	240	206	155	110	63	22
G	240	206	155	110	63	22
B	240	206	155	110	63	22

Product Specification

Dimension of viewing angle range.

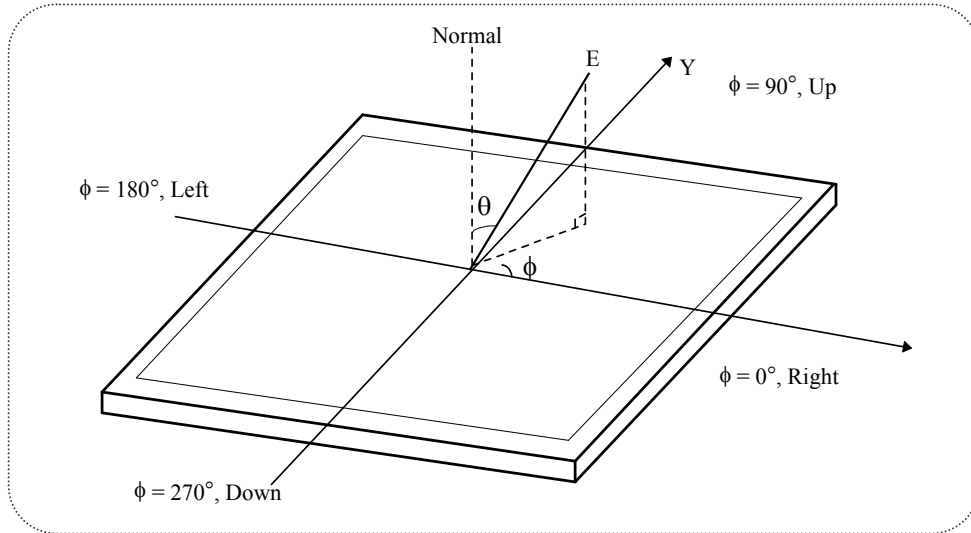

FIG. 7 Viewing angle

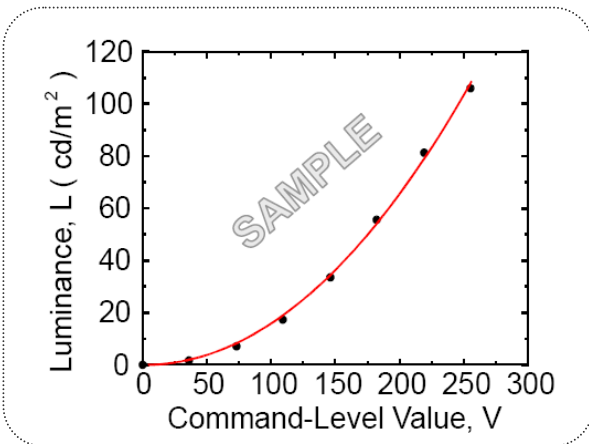

FIG. 8 Sample Luminance vs. gray scale (using a 256 bit gray scale)

$$L = aV^r + L_b$$

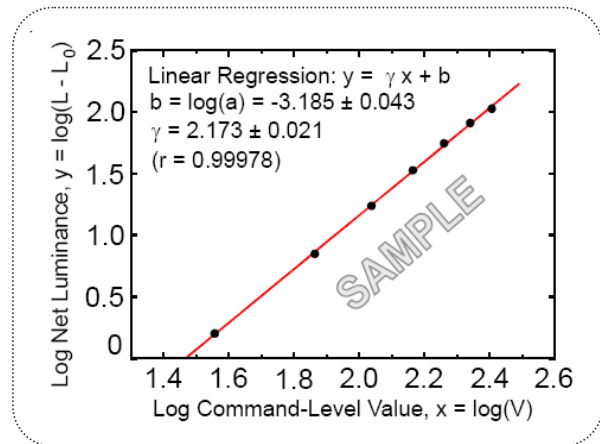

FIG. 9 Sample Log-log plot of luminance vs. gray scale

$$\log(L - L_b) = r \log(V) + \log(a)$$

Here the Parameter  $\alpha$  and  $\gamma$  relate the signal level  $V$  to the luminance  $L$ .  
The GAMMA we calculate from the log-log representation (FIG. 8)



**Product Specification****Table 10. Gray Scale Specification**

<b>Gray Level</b>	<b>Relative Luminance [%] (Typ.)</b>
0	0.10
31	1.08
63	4.71
95	11.5
127	21.7
159	35.5
191	53.1
223	74.5
255	100

**Product Specification**
**5. Mechanical Characteristics**

The contents provide general mechanical characteristics. In addition the figures in the next page are detailed mechanical drawing of the LCD.

Outline Dimension	Horizontal	630.0mm
	Vertical	368.2mm
	Depth	42.7mm (with inverter)
Bezel Area	Horizontal	601.8mm
	Vertical	340.6mm
Active Display Area	Horizontal	596.74mm
	Vertical	335.66mm
Weight	4,190g (Typ.) / 4,400g (Max.)	
Surface Treatment	Hard coating(3H) Anti-glare treatment of the front polarizer	

Notes : Please refer to a mechanic drawing in terms of tolerance at the next page.

Product Specification

<FRONT VIEW>

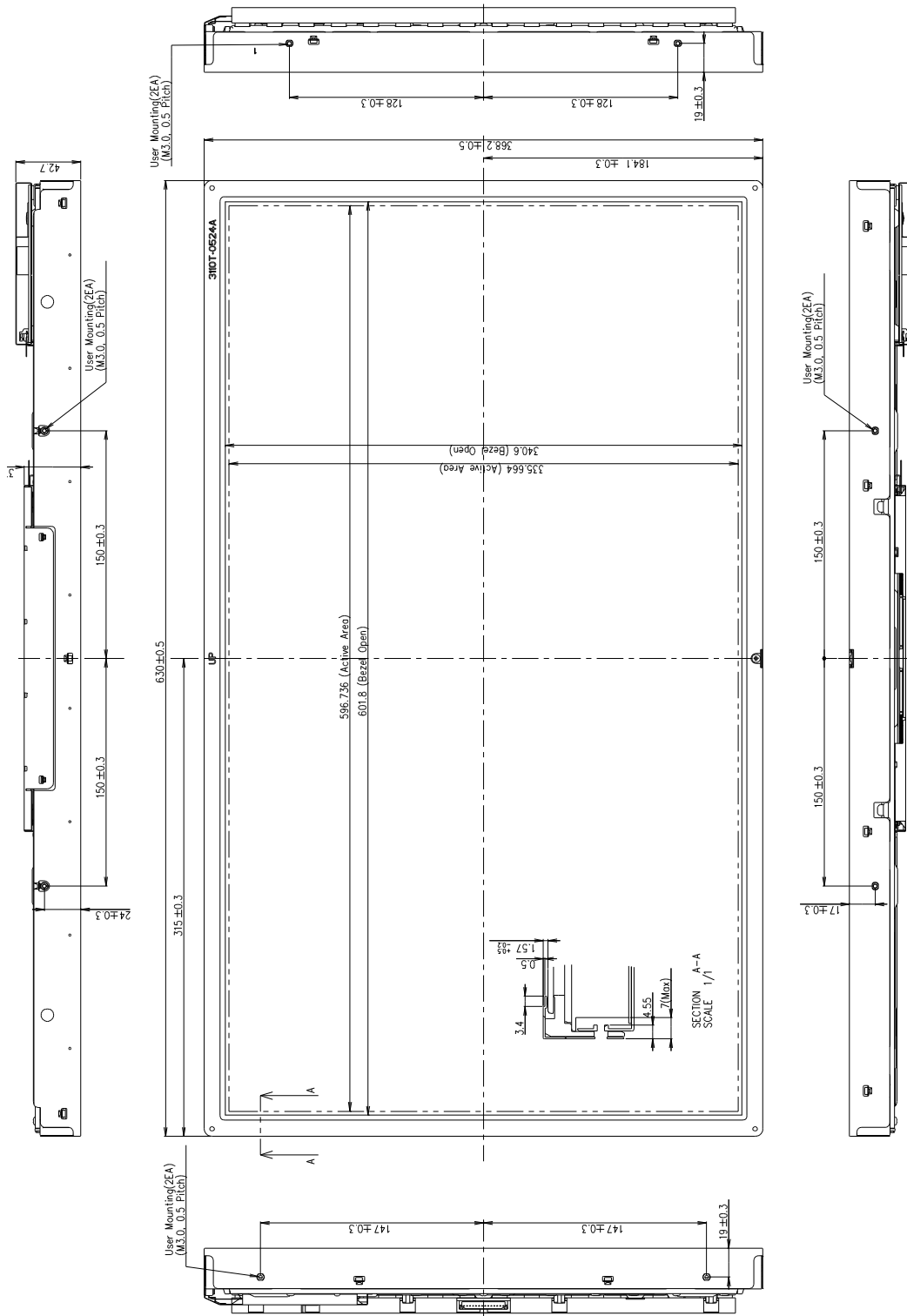

**Product Specification**

<REAR VIEW>

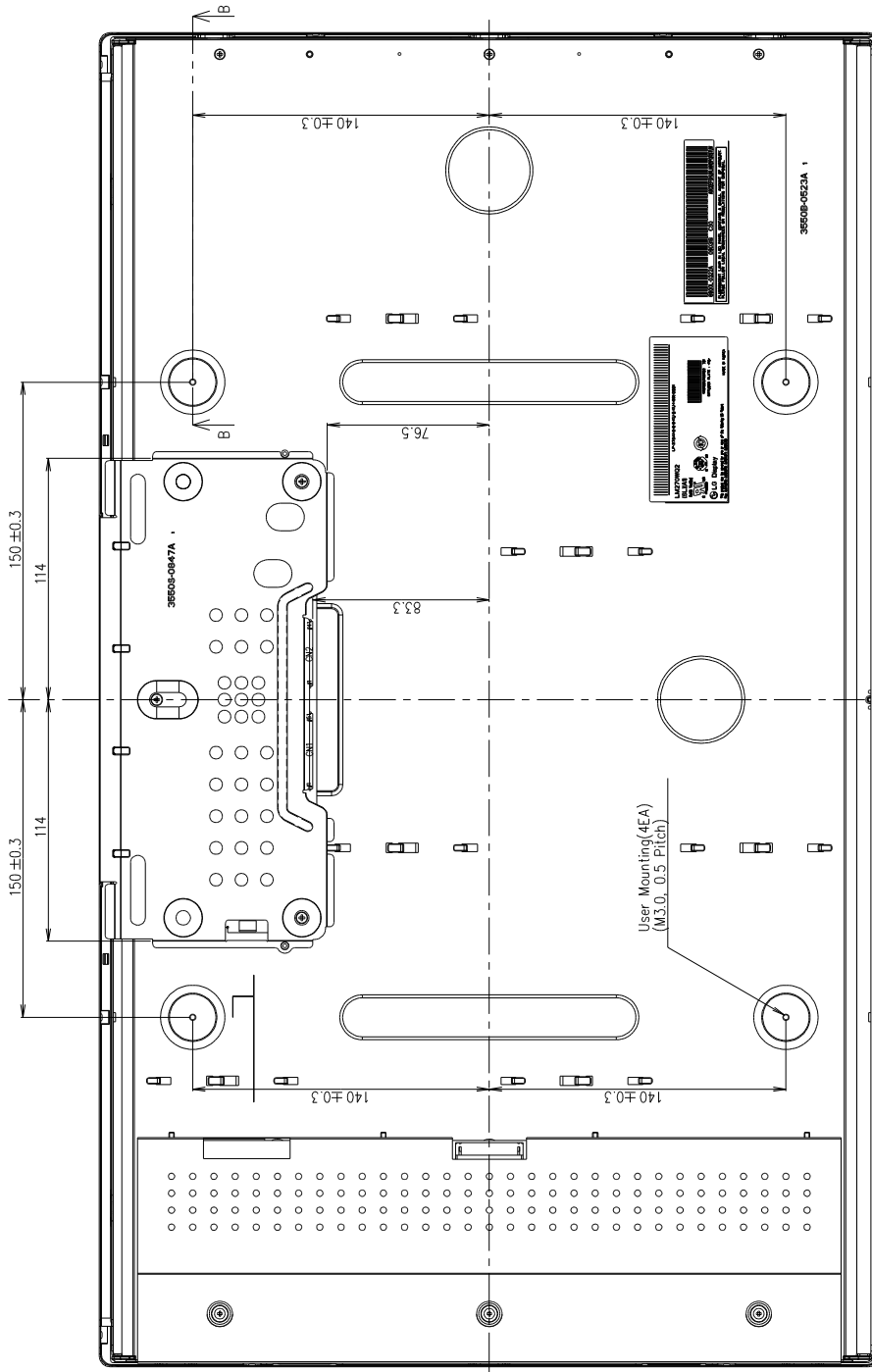

- Notes
1. Unspecified tolerances are to be  $\pm 0.5\text{mm}$ .
  2. Tilt and partial disposition tolerance of display area are as following.
    - (1) Y-direction :  $A-BI < 1.4\text{mm}$
    - (2) X-direction :  $IC-DI < 1.4\text{mm}$
  3. Torque SPEC of Mounting :  $6.0 \sim 7.0\text{kgf}\cdot\text{cm}$
  4. I/F Connector Specification : IS050-C51B-C39-A(CN1, UJU) , IS050-C41B-C39-A(CN2, UJU) or Compatible.

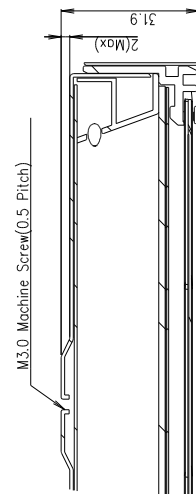
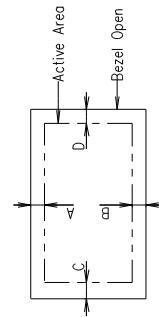

SECTION B-B  
SCALE 1/1

Product Specification

## 6. Reliability

Environment test condition

No	Test Item	Condition
1	High temperature storage test	Ta= 60°C 240h
2	Low temperature storage test	Ta= -20°C 240h
3	High temperature operation test	Ta= 50°C 50%RH 240h
4	Low temperature operation test	Ta= 0°C 240h
5	Vibration test (non-operating)	Wave form : random Vibration level : 1.0G RMS Bandwidth : 10-300Hz Duration : X,Y,Z, 10 min One time each direction
6	Shock test (non-operating)	Shock level : 100Grms Waveform : half sine wave, 2ms Direction : ± X, ± Y, ± Z One time each direction
7	Altitude Operating Storage / Shipment	0 - 10,000 feet(3,048m) 0 - 40,000 feet(12,192m)

## **7. International Standards**

### **7-1. Safety**

- a) UL 60950-1, Second Edition, Underwriters Laboratories Inc.  
Information Technology Equipment - Safety - Part 1 : General Requirements.
- b) CAN/CSA C22.2 No.60950-1-07, Second Edition, Canadian Standards Association.  
Information Technology Equipment - Safety - Part 1 : General Requirements.
- c) EN 60950-1:2006 + A11:2009, European Committee for Electrotechnical Standardization(CENELEC).  
Information Technology Equipment - Safety - Part 1 : General Requirements.
- d) IEC 60950-1:2005, Second Edition, The International Electrotechnical Commission (IEC).  
Information Technology Equipment - Safety - Part 1 : General Requirements.

### **7-2. EMC**

- a) ANSI C63.4 "American National Standard for Methods of Measurement of Radio-Noise Emissions from Low-Voltage Electrical and Electronic Equipment in the Range of 9 kHz to 40 GHz."  
American National Standards Institute (ANSI), 2003.
- b) CISPR 22 "Information technology equipment – Radio disturbance characteristics – Limit and methods of measurement." International Special Committee on Radio Interference (CISPR), 2005.
- c) CISPR 13 "Sound and television broadcast receivers and associated equipment – Radio disturbance characteristics – Limits and method of measurement." International Special Committee on Radio Interference (CISPR), 2006.

### **7-3. Environment**

- a) RoHS, Directive 2002/95/EC of the European Parliament and of the council of 27 January 2003

Product Specification

## 8. Packing

### 8-1. Designation of Lot Mark

a) Lot Mark



A,B,C : SIZE(INCH)  
E : MONTH

D : YEAR  
F ~ M : SERIAL NO.

Note

1. YEAR

Year	2001	2002	2003	2004	2005	2006	2007	2008	2009	2010
Mark	1	2	3	4	5	6	7	8	9	0

2. MONTH

Month	Jan	Feb	Mar	Apr	May	Jun	Jul	Aug	Sep	Oct	Nov	Dec
Mark	1	2	3	4	5	6	7	8	9	A	B	C

b) Location of Lot Mark

Serial No. is printed on the label. The label is attached to the backside of the LCD module.  
This is subject to change without prior notice.

### 8-2. Packing Form

a) Package quantity in one box : 5 pcs

b) Box Size : 747mm X 335mm X 466mm

**Product Specification****9. PRECAUTIONS**

Please pay attention to the followings when you use this TFT LCD module.

**9-1. MOUNTING PRECAUTIONS**

- (1) You must mount a module using holes arranged in four corners or four sides.
- (2) You should consider the mounting structure so that uneven force (ex. Twisted stress) is not applied to the module. And the case on which a module is mounted should have sufficient strength so that external force is not transmitted directly to the module.
- (3) Please attach the surface transparent protective plate to the surface in order to protect the polarizer. Transparent protective plate should have sufficient strength in order to resist external force.
- (4) You should adopt radiation structure to satisfy the temperature specification.
- (5) Acetic acid type and chlorine type materials for the cover case are not desirable because the former generates corrosive gas of attacking the polarizer at high temperature and the latter causes circuit break by electro-chemical reaction.
- (6) Do not touch, push or rub the exposed polarizers with glass, tweezers or anything harder than HB pencil lead. And please do not rub with dust clothes with chemical treatment. Do not touch the surface of polarizer for bare hand or greasy cloth.(Some cosmetics are detrimental to the polarizer.)
- (7) When the surface becomes dusty, please wipe gently with absorbent cotton or other soft materials like chamois soaks with petroleum benzene. Normal-hexane is recommended for cleaning the adhesives used to attach front / rear polarizers. Do not use acetone, toluene and alcohol because they cause chemical damage to the polarizer.
- (8) Wipe off saliva or water drops as soon as possible. Their long time contact with polarizer causes deformations and color fading.
- (9) Do not open the case because inside circuits do not have sufficient strength.

**9-2. OPERATING PRECAUTIONS**

- (1) The spike noise causes the mis-operation of circuits. It should be lower than following voltage :  
 $V = \pm 200\text{mV}$ (Over and under shoot voltage)
- (2) Response time depends on the temperature.(In lower temperature, it becomes longer.)
- (3) Brightness depends on the temperature. (In higher temperature, it becomes lower.)  
And in lower temperature, response time(required time that brightness is stable after turned on) becomes longer.
- (4) Be careful for condensation at sudden temperature change. Condensation makes damage to polarizer or electrical contacted parts. And after fading condensation, smear or spot will occur.
- (5) When fixed patterns are displayed for a long time, remnant image is likely to occur.
- (6) Module has high frequency circuits. Sufficient suppression to the electromagnetic interference shall be done by system manufacturers. Grounding and shielding methods may be important to minimized the interference.
- (7) Please do not give any mechanical and/or acoustical impact to LCM. Otherwise, LCM can't be operated its full characteristics perfectly.
- (8) A screw which is fastened up the steels should be a machine screw.  
(if not, it causes metallic foreign material and deal LCM a fatal blow)
- (9) Please do not set LCD on its edge.
- (10) It is recommended to avoid the signal cable and conductive material over the inverter transformer for it can cause the abnormal display and temperature rising.
- (11) Partial darkness may happen during 3~5 minutes when LCM is operated initially in condition that luminance is under 40% at low temperature (under 5℃). This phenomenon which disappears naturally after 3~5 minutes is not a problem about reliability but LCD characteristic



### **9-3. ELECTROSTATIC DISCHARGE CONTROL**

Since a module is composed of electronic circuits, it is not strong to electrostatic discharge. Make certain that treatment persons are connected to ground through wrist band etc. And don't touch interface pin directly.

### **9-4. PRECAUTIONS FOR STRONG LIGHT EXPOSURE**

Strong light exposure causes degradation of polarizer and color filter.

### **9-5. STORAGE**

When storing modules as spares for a long time, the following precautions are necessary.

- (1) Store them in a dark place. Do not expose the module to sunlight or fluorescent light. Keep the temperature between 5°C and 35°C at normal humidity.
- (2) The polarizer surface should not come in contact with any other object.  
It is recommended that they be stored in the container in which they were shipped.

### **9-6. HANDLING PRECAUTIONS FOR PROTECTION FILM**

- (1) The protection film is attached to the bezel with a small masking tape.  
When the protection film is peeled off, static electricity is generated between the film and polarizer. This should be peeled off slowly and carefully by people who are electrically grounded and with well ion-blown equipment or in such a condition, etc.
- (2) When the module with protection film attached is stored for a long time, sometimes there remains a very small amount of glue still on the bezel after the protection film is peeled off.
- (3) You can remove the glue easily. When the glue remains on the bezel surface or its vestige is recognized, please wipe them off with absorbent cotton waste or other soft material like chamois soaked with normal-hexane.